



"Making the World's Food Safer"



Romer Series II™ Mill Manual

Version: SIIMM01.3

30 November, 2001

Romer® Labs, Inc.

1301 Stylemaster Drive

Fax: (636) 583 6553

www.romerlabs.com

Union, MO 63084-1156

Tel: (636) 583 8600

sales@romerlabs.com

Toll free: (800) 769 1380



Table of Contents

Introduction.....	3
Safety Information	4
Romer Series II™ Mill Protection Guidelines	5
Operation and Grinding Procedure	6
Grinder Knob Adjustments.....	6
Cleaning and Care	7
Specifications	8
Sampling Procedures	9
Technical Service Guide	13
Replacement Parts.....	14
Warranty.....	15
Fax Order Form	16
Routine Maintenance Log	17



Romer® Labs, Inc.

Introduction

Thank you for purchasing the Romer® Labs, Inc. Series II™ Mill (U.S. Patent #4,679,737). The Romer Series II™ Mill is a versatile and easy to use mill that will meet your sample preparation and sample grinding needs for a variety of analyses. This mill is designed to grind and sub-sample human foods, animal feeds and feed ingredients. Other uses are not advised.

The Romer Series II™ Mill has several features including:

- Each kernel is sub-sampled as it is ground which yields accurate results and minimal false negatives.
- Grinds 2 lbs (1 kg) per minute, which may reduce labor.
- Easy cleaning prevents cross-contamination.
- Large hopper holds up to 15 lbs (approximately 7 kg) of corn.
- Minimal amounts of heat and dust are generated.
- Lightweight, portable and requires no assembly.

Each Romer Series II™ Mill is quality control checked prior to shipment.

****All 230V mills are CE approved.**



Safety Information

Safety should always be the first concern when operating the Romer Series II™ Mill. The following guidelines have been written for your protection. Always use caution when operating any piece of equipment.

To avoid personal injury:

- Always wear a dust respirator to prevent the inhalation of toxic materials.
- Wear protective eye gear; goggles, safety glasses or other approved eyewear.
- Use the mill only with a grounded 3-prong plug or damage to the unit may occur.
- Make sure the mill is on a level surface.
- Use in a well ventilated area, such as a fume hood, etc.
- Replace fuses as outlined in the Specifications section of his manual.

DO NOT:

- Operate the mill with any part removed (chutes, motor cover, etc.).
- Plug in the unit while the power switch is in the "on" position.
- Use the mill for any purpose other than those stated in this manual.
- Disassemble or otherwise attempt to service this unit unless the power cord is disconnected.

Romer Series II™ Mill Protection Guidelines

The Romer Series II™ Mill is provided with a shear disk drive release to protect the motor and burrs if a foreign object, such as a nail or rock, gets into the mill. If the motor will run, but no sample is discharged, check to make sure the circuit breaker has not been tripped. If the breaker is not tripped, the shear disk must be replaced.

To replace the shear disk, follow the steps listed below:

1. Remove grinder cap assembly.
2. Pull off shear cap.
3. Pull out revolving burr assembly.
4. Insert new shear disk drive and before reassembling, check to assure that:
 - no obstruction is caught between the teeth of either burr
 - the tension spring is on the motor shaft
 - no dust has built up on the surface of the grinder cap which may prevent the it from seating properly against the grinder head.
5. During reassembly, make sure the thrust plug is attached to the inside of the grinder cap assembly.
6. Gradually turn one grinder cap screw, then the other until both are tight. Do Not completely tighten one screw without equally tightening the other.

The Romer Series II™ Mill is provided with a breaker switch on the back of the motor cover. If the motor becomes too hot, the breaker switch will release and the motor will stop. Overheating of the motor is usually due to grinding commodities that contain excess moisture (over 20%) or fat (almonds, peanuts, etc.). After the motor has cooled, set the grind lever as far as it will turn counter-clockwise. Reset the breaker switch and resume grinding. Do not grind high moisture or high fat commodities on the fine grind setting.

Do not connect mill to an overloaded line as serious damage to the motor may result. If the current fails or a fuse blows while the mill is in operation, turn the grind lever left (mill standing upright) as far as it will go, then turn the mill “off” before troubleshooting. When the current is available, allow the mill to operate for 10-15 seconds and then reset the grind lever to the original setting.

There is no need for further oiling of the Romer Series II™ Mill bearings.



Operation and Grinding Procedure

1. Visually inspect sample for any rocks, metal objects or other foreign material, which may damage the mill. If the commodity contains dust, wear a fine mesh dust mask or other appropriate apparatus for inhalation safety.
2. Open restrictor lever one or two notches to the left to allow approximately 20% of the ground commodity to exit the front chute.
3. Set grind adjust cap for desired sample particle size.
4. Turn power switch to the “on” position.
5. Fill hopper with sample and allow sample to grind through the mill. Collect analytical sample from the front chute.
6. Using a spatula, thoroughly mix the contents of the sample collected from the front chute for approximately 30 seconds. This is a critical step that ensures even mixture of the sample.
7. Clean the mill thoroughly after each use (see Cleaning and Care section).

Grinder Knob Adjustments

The grinder cap can be adjusted to give different particle sizes, however different commodities will grind to different particle sizes when using the same setting. For example, corn will grind to a larger particle size than wheat when using the same setting. To obtain a larger particle size, turn the grinder knob to the left with the mill standing upright. To obtain a smaller particle size, turn the grinder knob to the right with the mill standing upright.

To grind high fat or high moisture products, it may be necessary to adjust the grinder cap to a coarse grind setting.

The Romer Series II™ Mill has been preset at Romer® Labs, Inc., but over time, the burr set (grinding assembly inside the grinder housing) may become worn and need adjustment. To adjust the burr set, follow the procedure listed below.

1. Turn the power switch to the “off” position.
2. With the mill lying on it's back, as featured in the photo on the next page, adjust the grinder knob to the farthest clockwise position.
3. Loosen the outside locking screws on the grinder knob.
4. Turn the power switch to the “on” position.
5. Slowly turn the grind adjustment screw clockwise until a faint grinding sound is heard. Then slowly turn the grind adjustment screw counter-clockwise 1/8 of a turn until the burr set no longer makes a grinding noise.
6. After setting the burr set, tighten the locking screws.
7. To achieve a larger particle size, turn the grind adjustment screw counter-clockwise in step 5 and tighten the locking screws.

Cleaning and Care

A small amount of ground sample may remain in the mill after the total sample has been ground and a subsample collected. To prevent cross-contamination, use one of the following procedures to clean the mill after each use.

1. After the sample is completely ground and while the unit is still running, cover the chute openings with an attachment of an operating vacuum cleaner at the bottom of each sub-sampling chute. Vacuum for approximately 30 seconds.
2. Run approximately 50 grams of the next sample through the grinder and discard. Grind the remaining sample.

To fully clean the burr set, turn the power switch to the “off” position and unplug the unit. Remove the grinding assembly by following the steps in “Romer Series II™ Mill Protection Guidelines” that detail how to replace the shear pin. Periodically check the burr set and inside the grinder housing to remove any built-up residue. This area should be thoroughly cleaned every week with a stiff brush. Soap and water may also be used.

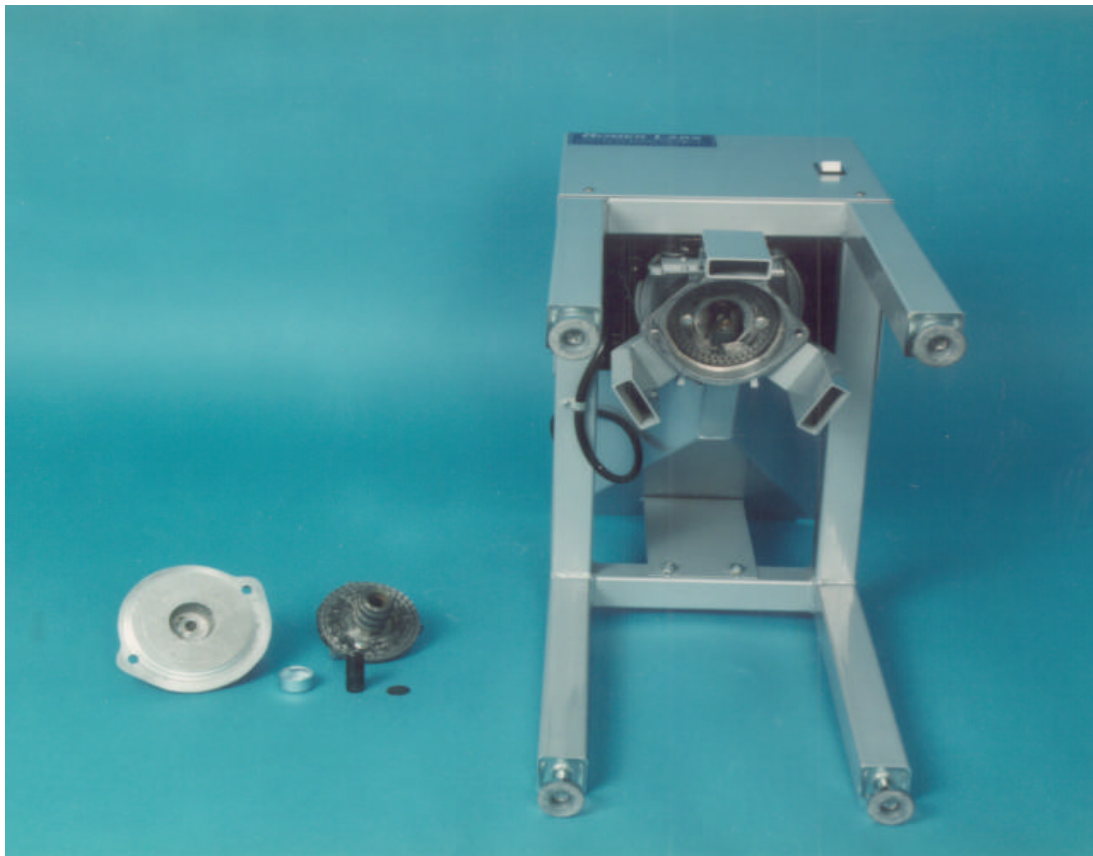

Specifications

Grinding Burrs: Nihard Metal Alloy
Grinder Housing: Cast Aluminum
Feedworm: Cast Iron
Shear Drive: Stainless Steel with black oxide finish

Current:	AC only	Height:	26 ³ / ₄ '
Voltage (AC):	115V or 230V	Width:	11 ¹ / ₄ '
Motor: 115V (AC):	1/2HP	Depth:	19 ¹ / ₄ '
230V (AC):	1/2HP	Breaker: 115V (AC):	10 Amp
Weight:	60 lbs/ 27.3 kg	230V (AC):	5 Amp

FEATURES

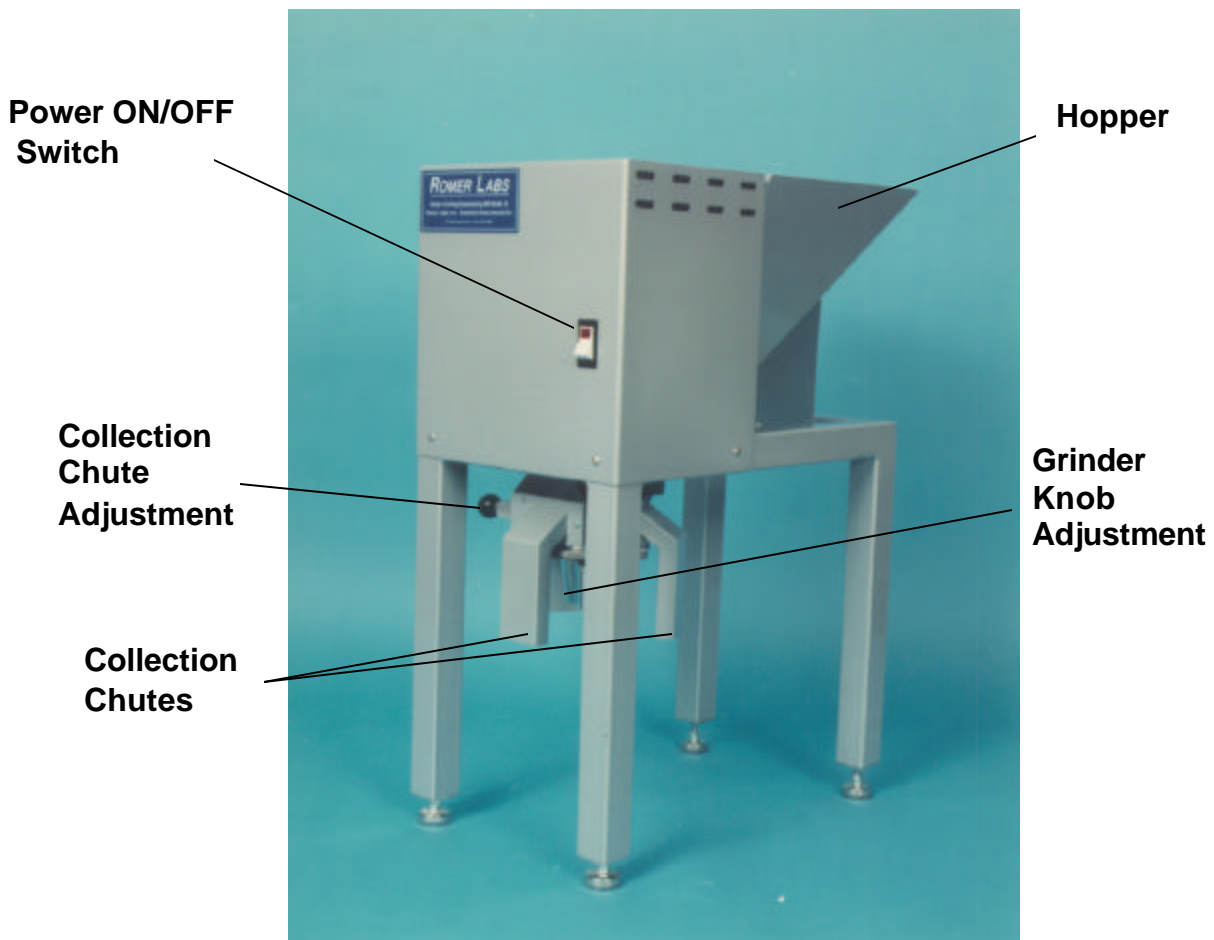



Sampling Procedures for Mycotoxin Analysis

Proper sampling and sample preparation is the foundation of quality mycotoxin testing. This is the most crucial step in obtaining accurate mycotoxin test results and is very often overlooked. Without a properly obtained and prepared sample, mycotoxin test results will have a high degree of analytical variability.

Please consult your Romer® Labs, Inc representative for a copy of the Romer® Labs, Inc. Guide to Mycotoxins, Volume 2 entitled “Sampling and Sample Preparation for Mycotoxin Analysis”. This publication outlines the proper procedures for sampling and sample preparation.

The first objective is obtain a representative sample of whole grain, finished feed or meal from rail cars, truck lots, storage bins, or feeding pans and troughs.

A. Sampling Equipment:

1. Manual Sampling:

- Grain probe or trier (barges, box cars, trucks, hopper containers - see Fig. 1)
- Bag trier (sacked grains - see Fig. 2)
- Pelican sampler (sampling grain in a falling stream)

2. Pneumatic or Hydraulic Probes (terminal elevator or processing plant probe)

3. Mechanical sampling systems

- Diverter-type (automatic sampling of sections or cuts of entire grain flow)
- Point-type (auger sampling of powdered commodities)

B. Sampling Patterns (large grain carriers, storage bins or troughs):

1. Flat-bottom trucks or trailers containing grain more than 4 feet (1.2 m) deep should use a 7- probe pattern with each trailer treated as a separate load. Flat-bottom trucks or trailers containing grain less than 4 feet (1.2 m) deep should use a 9-probe pattern (Fig. 3)
2. Hopper car (3-compartment, through or door type), insert probe vertically at a 10-degree angle in the center or slightly off center in order to miss the cross beam (Fig. 4)
3. Lift-top and roll-top barges, draw the first probe 4 feet from the stern end of the barge and 7 feet from the side. Take remaining probes at 15-foot intervals to the bow end of the barge. The last probe is taken 4 feet from the box end and 7 feet from the side (Fig. 5)
4. Storage Bins should use automatic pneumatic or mechanical sampling equipment or an adequate probe. If this is not possible, collect 5 probes of feed or meal or 9 probes of whole grain according to the sampling pattern (Fig. 6). Collect about 0.5 lbs. from the bottom of the bin using an auger and combine this with the probed sample. If moisture accumulation is suspected, use the probe pattern (Fig. 7) to collect potentially moist material from the edges of the

bin separately and potentially less moist material from the center of the bin. Transfer the edges-sample and the center-sample to two separate sample bags, close securely and store under dry, cool conditions until analyzed. Label the one sample as "Storage Bin Edges" and the other as "Storage Bin Center".

5. Pans and Troughs

- Pans in Poultry House: Collect twelve 75 gram grab samples in sample bag, 4 at the first station the feed reaches, 4 at the middle station and 4 at the last station the feed reaches. Fasten bag securely and store under dry, cool conditions until analyzed.
- Troughs: In the sample bag provided, collect twelve 75-gram grab samples randomly from trough. Take some samples from each section of the trough. Close bag securely and store under dry, cool conditions until analyzed.

6. During Loading or Unloading

The only practical way to obtain a representative sample from a storage bin is during the loading or unloading process. Either automatic sampling equipment or grab samples can be used. Collect a series of 50 to 100 gram samples, as the grain is being loaded or unloaded. A total of 5 lb. of whole grain and 2 lb. of meal or finished feed should be obtained. Take the first sample as soon as the loading begins and the last one near the end of the loading. Transfer the total sample collected to a sample bag, close securely, and store under dry, cool conditions until analyzed.

C. Proper Sample Size

By taking a sample that is too small, the toxins are either missed completely, or found at much lower levels than truly present. Adequate sample size is important for accurate mycotoxin analytical results:

1. Minimum Sample Size for Corn or Green Coffee: 5 lbs or approximately 2.5 kg
2. Minimum Sample Size for Wheat or Barley: 3 lbs or approximately 1.5 kg
3. Minimum Sample Size for Flour: 3 lbs or approximately 1.5 kg

Manual Probes

Figure 1

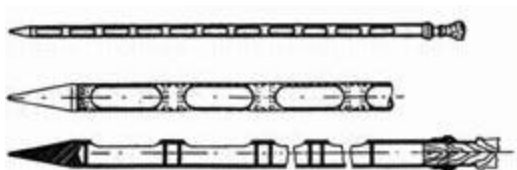
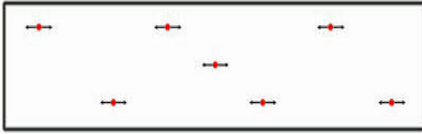

Figure 2



Figure 3 – Flat –bottom trucks or trailers

7-Probe Pattern



9-Probe Pattern

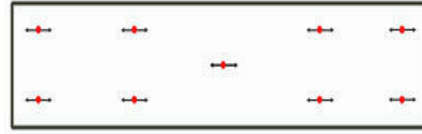

Figure 4 – Hopper Cars

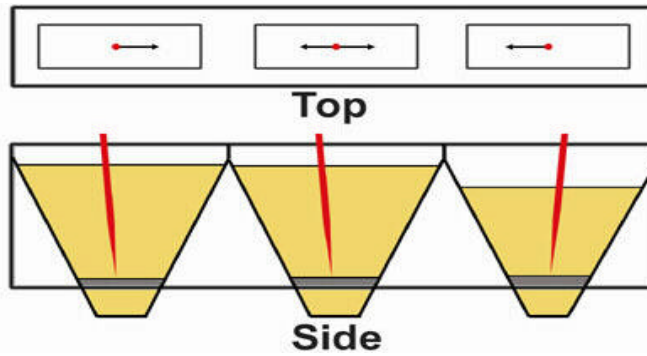

Figure 5 – Lift-top Barges

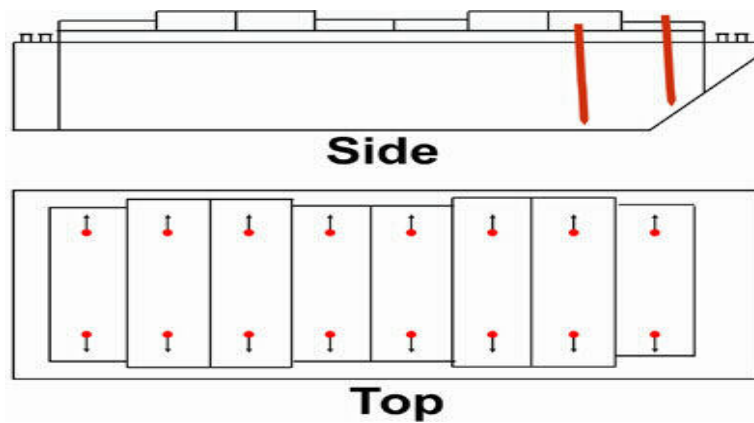

Figure 6 – Storage Bin:

Feed or Meal: 5 – Probe Pattern
Whole Grain: 9 – Probe Pattern

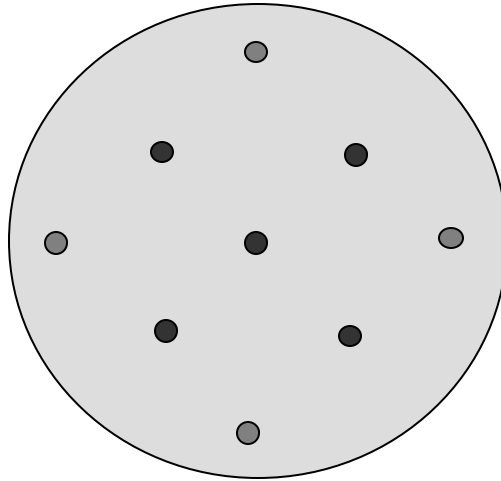
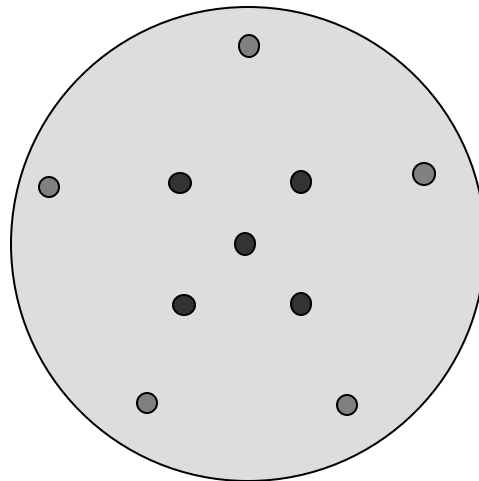

Figure 7 – Storage Bin (Moisture Accumulation)





Technical Service Guide

Problem	Corrective Action
Mill does not run with power on.	Be sure power cord is plugged in and there is a power supply to mill. Reset circuit breaker to “in” position.
Mill runs but grain is not being ground	Check chutes for blockage. Check hopper for blockage. Break up sample so that it can be ground through mill. Check shear disk and replace if necessary.
Mill stops during grinding and appears hot.	Let mill cool and reset circuit breaker to “in” position. Adjust grinding assembly for a coarser grind.
Thrust plug is chipped or missing.	Replace thrust plug.
Burrs make grinding noise while running with no sample in the mill.	Adjust burr set.

If you have questions concerning the mill, please contact Romer® Labs, Inc at:
1-800-769-1380 or 636-583-8600

Replacement Parts

Part #	Description	Item number
1	Grinder cap assembly (includes: grinder cap, grind knob, detent spring, detent plate, grind adjustment screw, two 10-32 x 1/2 screws, adjusting bearings and detent plunger)	EQMMP2090
2	Shear drive assembly (includes shear drive, 25 shear discs, shear cap and thrust plug)	EQMMP2230
3	Feed worm with bushings	EQMMP2060
4	Burr set	EQMMP2030
5	Grinder head assembly (includes: grinder head, restrictor gate, restrictor door, left, right and collection chute)	EQMMP2110
	Breaker, 10 Amp.	EQMMP2010
	Thrust plug (pkg. of 5)	EQMMP2260
	Tension springs (pkg. of 3)	EQMMP2250

Exploded diagram of the Romer Series II™ Mill assembly:

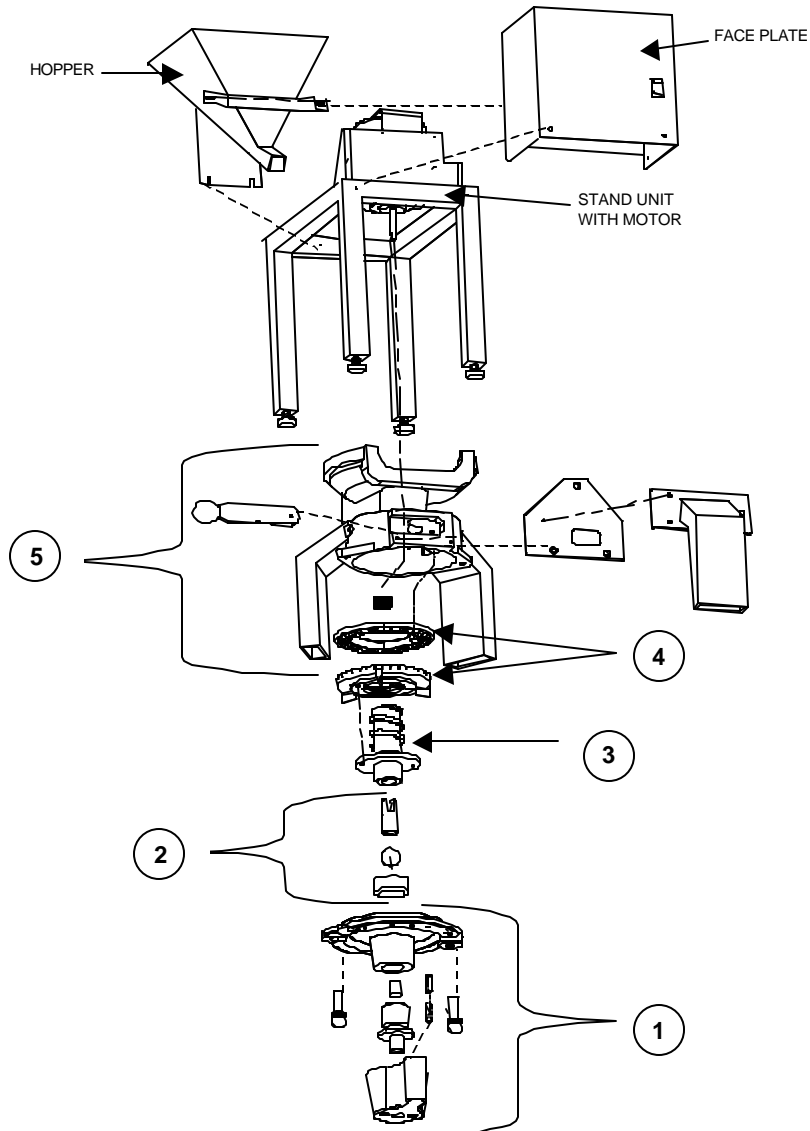



Romer® Labs, Inc.

Warranty

The Series II™ Mill is guaranteed by Romer® Labs, Inc. to be free of defects in workmanship and materials under normal use for a period of ninety (90) days from the date of purchase by the consumer. Romer® Labs, Inc. designates the right to determine a products warranty status.

All liability of Romer® Labs, Inc. is limited to the repair or replacement of the mill. Under no circumstances is Romer Labs, Inc. liable for consequential damage or loss. Instruments and accessories subjected to misuse, abuse, neglect, modification or unauthorized repair constitute exclusion from warranty.

All warranty claims must be directed to:

Romer® Labs, Inc.
1301 Stylemaster Drive
Union, MO 63084-1156

Phone: (636) 583-8600
Fax: (636) 583-6553

© 2001 by Romer® Labs, Inc. Union, MO

All rights reserved. No part of this manual may be reproduced in any form or by any means, without expressed written consent from Romer® Labs, Inc. Photocopying is prohibited.



Fax order form

Romer® Labs, Inc.

Please fax your order to: (636) 583 2793

For technical customer service, call toll free:
(800) 769 1380

BILL TO	SHIP TO
Name:	<input type="checkbox"/> same as "bill to" address
Company:	Name:
Address:	Company:
.....	Address:
.....
Tel:
Fax:	Tel:
Purchase order #:	Fax:

Method of Payment	Method of Shipping
<input type="checkbox"/> Bill company (upon approval of credit)	<input type="checkbox"/> UPS Next Day Air
<input type="checkbox"/> VISA <input type="checkbox"/> Master card <input type="checkbox"/> American Express	<input type="checkbox"/> UPS Second Day Air
Card number: -----	<input type="checkbox"/> UPS 3 Day Select
Exp. Date: -- / --	<input type="checkbox"/> UPS Groundtrac
Signature:	<input type="checkbox"/> Federal Express, Account #:
	<input type="checkbox"/> DHL

Item Number	Description	Quantity	Unit Price (US\$)

For Romer® Labs, Inc. shipping dept. only

Date shipped:

Invoice #:

UPS tracking numbers

Shipping Charge:

Credit card authorization #:

Ref #: Batch#:

